

Antrieb Unterhalb in LR links

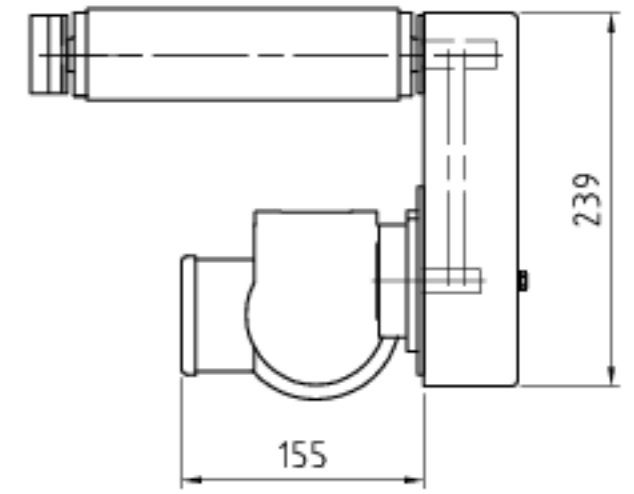

Antrieb Oberhalb in LR links

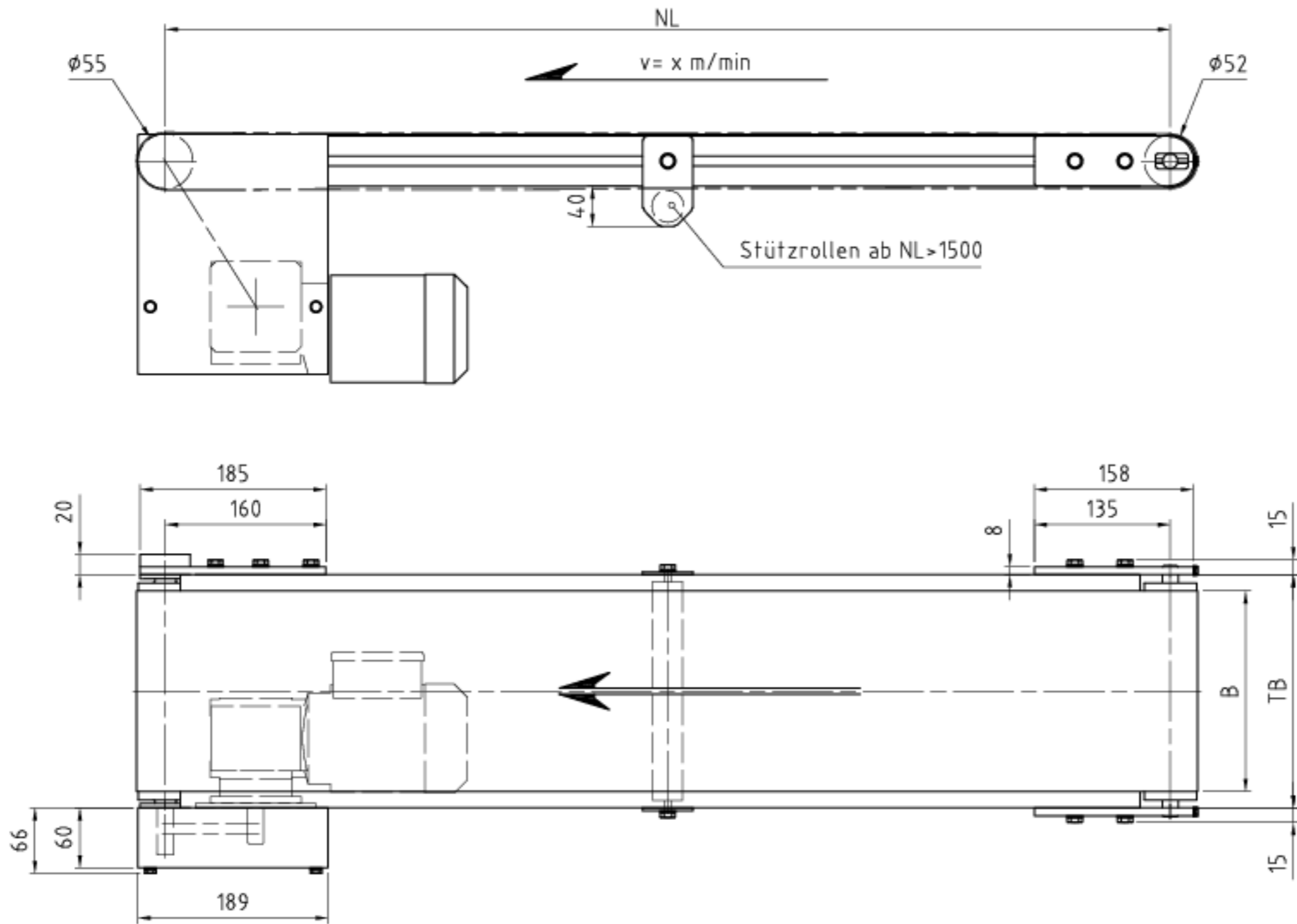
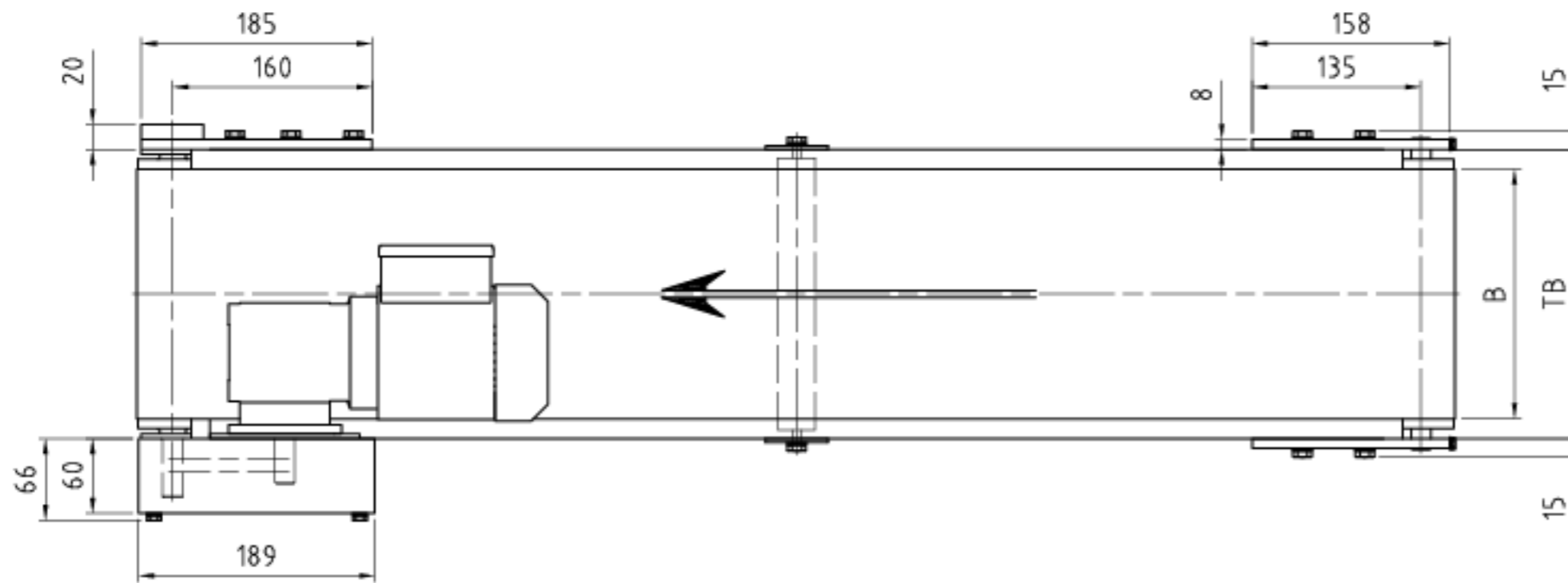
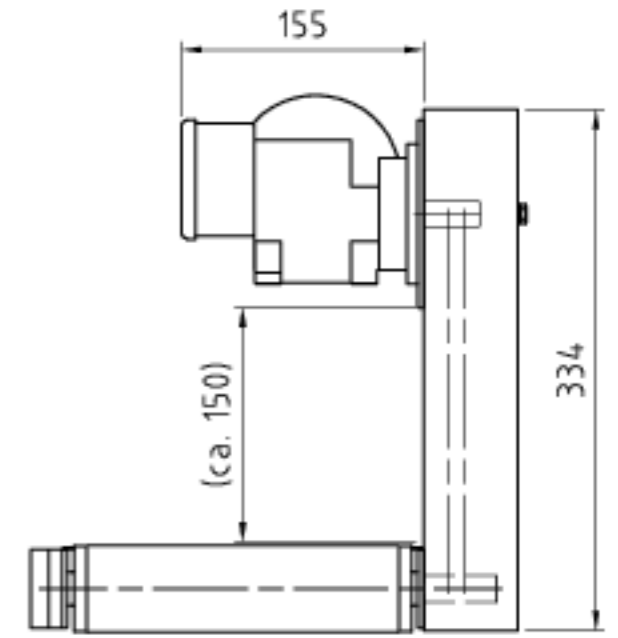
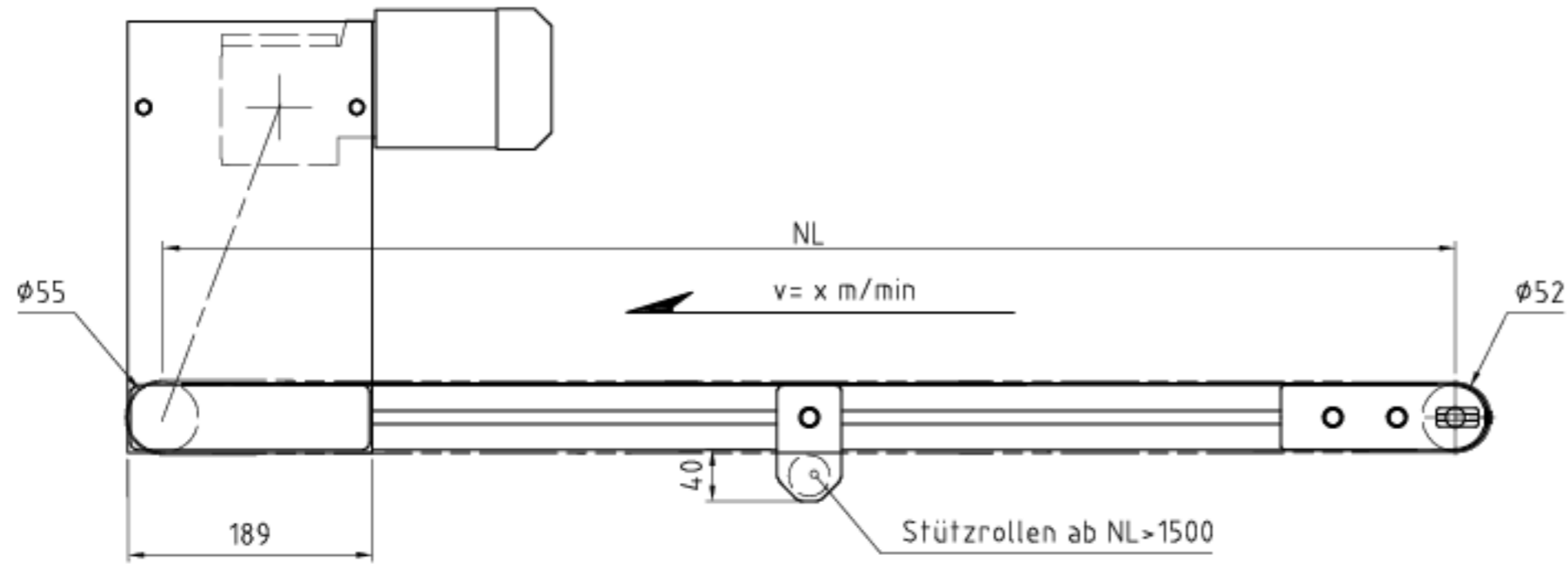

Antrieb Seitlich direkt in LR links

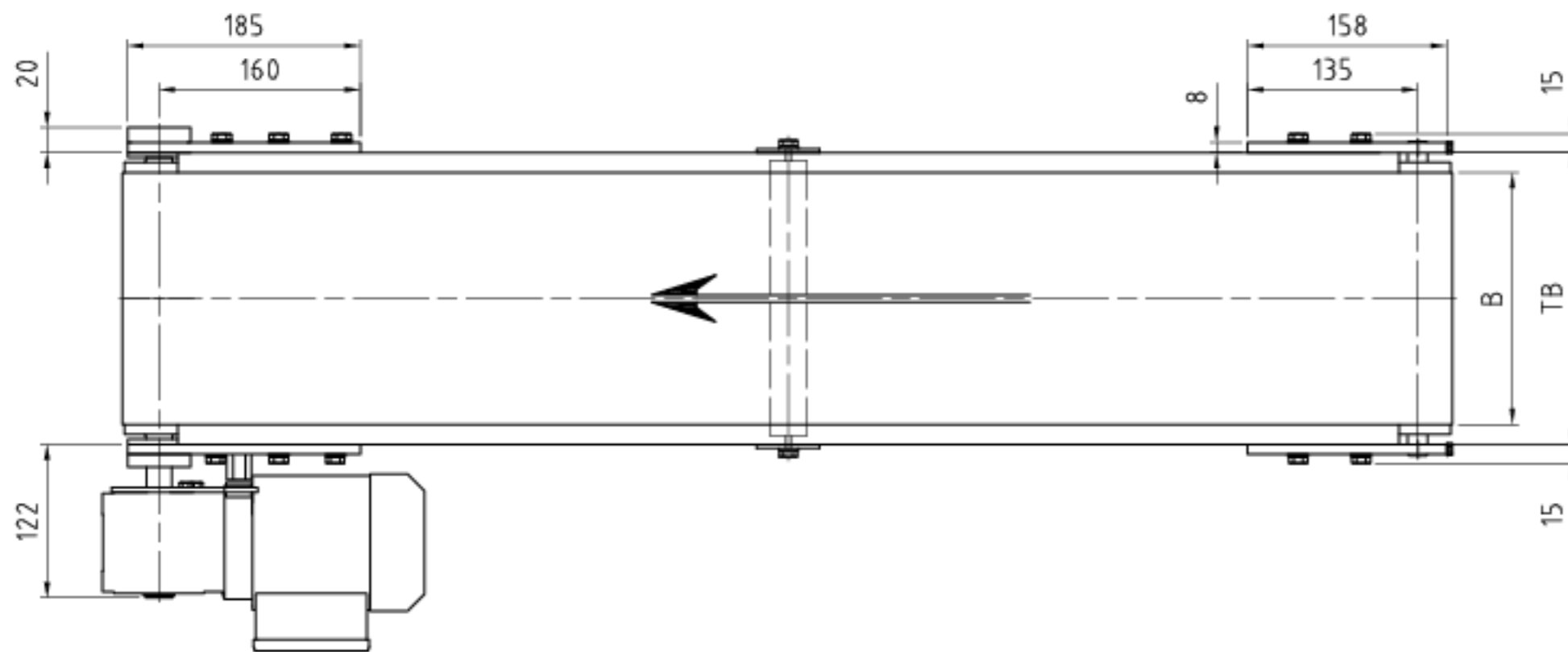
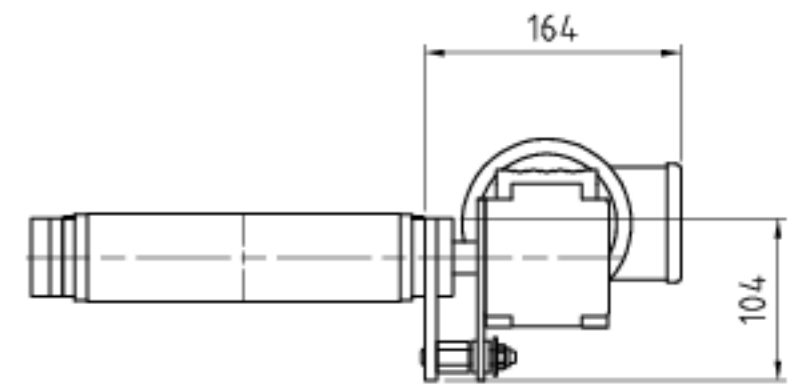
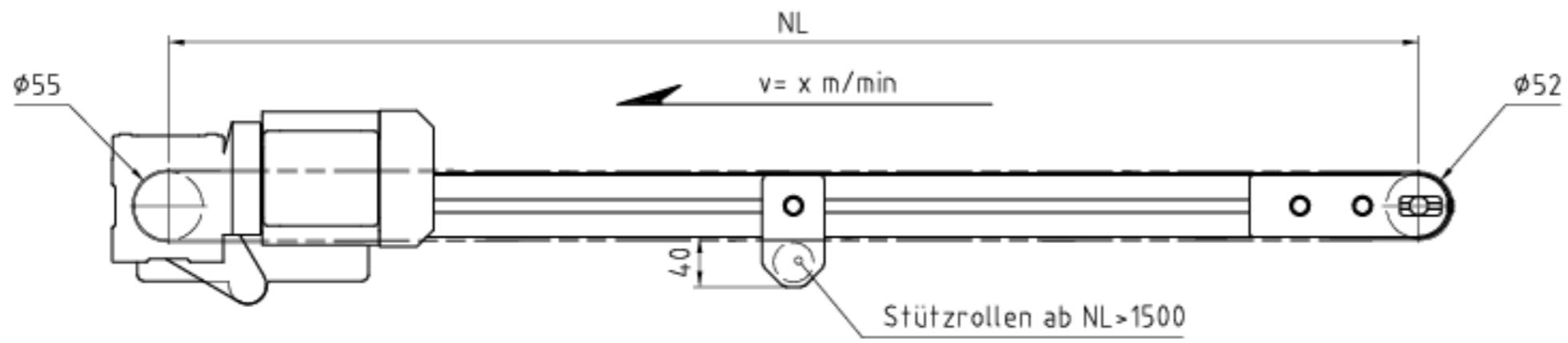

Trommelmotor Kabelausführung in LR links

